



ORIENT

Photo coupler

Product Data Sheet

MPN: ORPC-817-S series of SJ

Customer: _____

Date: _____

SHENZHEN ORIENT COMPONENTS CO., LTD

Block A3rd Floor No.4 Building, Tian'an Cyber Park, Huangge Rd, LongGang Dist, Shenzhen, GD

TEL: 0755-29681817

FAX: 0755-29681200

www.orient-opto.com

Preliminary

This datasheet is a preliminary design specification, and the formal specifications are subject to the recognition letter with jointly signed

1. Features

- (1) Current transfer ratio (CTR : MIN. 50% at $I_F = 5\text{mA}$, $V_{CE} = 5\text{V}$)
- (2) High input-output isolation voltage ($V_{iso} = 5,000\text{Vrms}$)
- (3) Response time (t_r : TYP. $4\mu\text{s}$ at $V_{CE} = 2\text{V}$, $I_C = 2\text{mA}$, $R_L = 100\Omega$)
- (4) Operating Temperature $-55\text{ }^\circ\text{C}$ to $110\text{ }^\circ\text{C}$
- (5) ESD pass HBM 8000V/MM 2000V
- (6) Safety approval
 - UL approved (No.E323844)
 - VDE approved(No.40029733)
 - CQC approved (No.CQC09001029446)
 - CE approved (No.AC/0431008)
 - State Grid approved (No.SGCM013420240085)
- (7) In compliance with RoHS, REACH standards
- (8) MSL Class I



2. Description

- (1) ORPC-817-S-(SJ) photo coupler consist of one piece of GaAs emitter and one piece of NPN transistor.
- (2) Packaged in a 4-pin SMD package.

3. Applications

- (1) Switching power supply
- (2) Ammeter
- (3) Computer
- (4) Instrumental application, measurement machine
- (5) Signal transforming systems
- (6) Imbursement equipments, duplicating machine, automat
- (7) Family-use electric equipments, such as fans

4. Functional Diagram

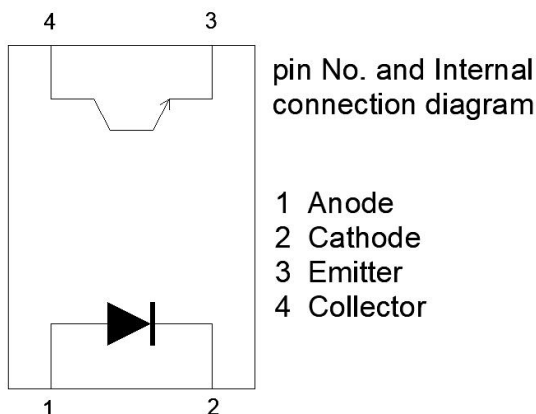

5. Absolute Maximum Ratings at Ta=25°C

Parameter		Symbol	Rated Value	Unit
Input	Forward Current	I_F	60	mA
	Peak forward Current (100µs pulse, 100Hz frequency)	I_{FP}	1	A
	Reverse Voltage	V_R	6	V
	Consume Power	P	70	mW
Output	Collector and emitter Voltage	V_{CEO}	80	V
	Emitter and collector Voltage	V_{ECO}	7	
	Collector Current	I_C	50	mA
	Consume Power	P_C	150	mW
Total Consume Power		P_{tot}	200	mW
*1 Insulation Voltage		V_{iso}	5000	Vrms
Maximum transient isolation voltage (Insulating oil test)		V_{IOTM}	8000	V_{peak}
Maximum repetitive peak isolation voltage		V_{IORM}	850	V_{peak}
Operation Temperature		T_{opr}	-55 to + 110	°C
Storage Temperature		T_{stg}	-55 to + 125	
*2 Soldering Temperature		T_{sol}	260	

*1.AC For 1 Minute, R.H. = 40 ~ 60%

Isolation voltage shall be measured using the following method.

- (1) Short between anode and cathode on the primary side and between collector and emitter on the secondary side.
- (2) The isolation voltage tester with zero-cross circuit shall be used.
- (3) The waveform of applied voltage shall be a sine wave.

*2. Soldering time is 10 seconds

6. Electro-Optical Characteristics (Ta=25°C unless specified otherwise)

Parameter		Symbol	Min	Typ.*	Max	Unit	Condition
Input	Forward Voltage	V _F	---	1.2	1.4	V	I _F =20mA
	Reverse Current	I _R	---	---	5	μA	V _R =5V
	Collector Capacitance	C _t	---	30	250	pF	V=0, f=1KHz
Output	Collector to Emitter Current	I _{CEO}	---	---	100	nA	V _{CE} =20V, I _F =0mA
	Collector and Emitter Breakdown Voltage	BV _{CEO}	80	---	---	V	I _C =0.1mA I _F =0mA
	Emitter and Collector Breakdown Voltage	BV _{ECO}	7	---	---	V	I _E =0.1mA I _F =0mA
Transforming Characteristics	*1 Current conversion ratio	CTR	50	---	600	%	I _F =5mA V _{CE} =5V
	Collector Current	I _C	2.5	---	30	mA	
	Collector and Emitter Saturation Voltage	V _{CE(sat)}	---	0.1	0.2	V	I _F =20mA I _C = 1mA
	Insulation Resistance	R _{iso}	5×10 ¹⁰	1×10 ¹²	---	Ω	DC500V 40~60%R.H.
	Floating Capacitance	C _f	---	0.6	1.0	pF	V=0, f=1MHz
	Cut-off Frequency	f _c	---	80	---	kHz	V _{CE} =5V, I _C =2mA R _L =100Ω,-3dB
	Rise Time	t _r	---	4	18	μs	V _{CE} =2V, I _C =2mA R _L =100Ω
	Fall Time	t _f	---	3	18	μs	

*1 Current Conversion Ratio = I_C / I_F × 100% , CTR Tolerance:±3%.

7. Rank Table of Current Transfer Ratio

CTR BIN	Min (%)	Max (%)	Condition
A	80	160	$V_{CE} = 5V / I_F = 5mA, T_a=25^{\circ}C$
	30	100	$V_{CE} = 5V / I_F = 1mA, T_a=25^{\circ}C$
B	130	260	$V_{CE} = 5V / I_F = 5mA, T_a=25^{\circ}C$
	50	150	$V_{CE} = 5V / I_F = 1mA, T_a=25^{\circ}C$
C	200	400	$V_{CE} = 5V / I_F = 5mA, T_a=25^{\circ}C$
	80	300	$V_{CE} = 5V / I_F = 1mA, T_a=25^{\circ}C$
D	300	600	$V_{CE} = 5V / I_F = 5mA, T_a=25^{\circ}C$
	120	400	$V_{CE} = 5V / I_F = 1mA, T_a=25^{\circ}C$

8. Order Information

Part Number

ORPC-817XT-V-W-Y-Z-(SJ)

Note

X = Lead form option (S, M or none)

T = CTR Rank (A, B, C, D or none)

V = Tape and reel option (TP, TP1 or none).

W = Lead frame option (F: Iron)

Y = 'G' code for Halogen free (HF only).

Z = 'S' process identification code.

SJ = Field code.

Option	Description	Packing quantity
S(TP)	Surface mount lead form (low profile) + TP tape & reel option	2000 units per reel
S(TP1)	Surface mount lead form (low profile) + TP1 tape & reel option	2000 units per reel

9. Naming Rule

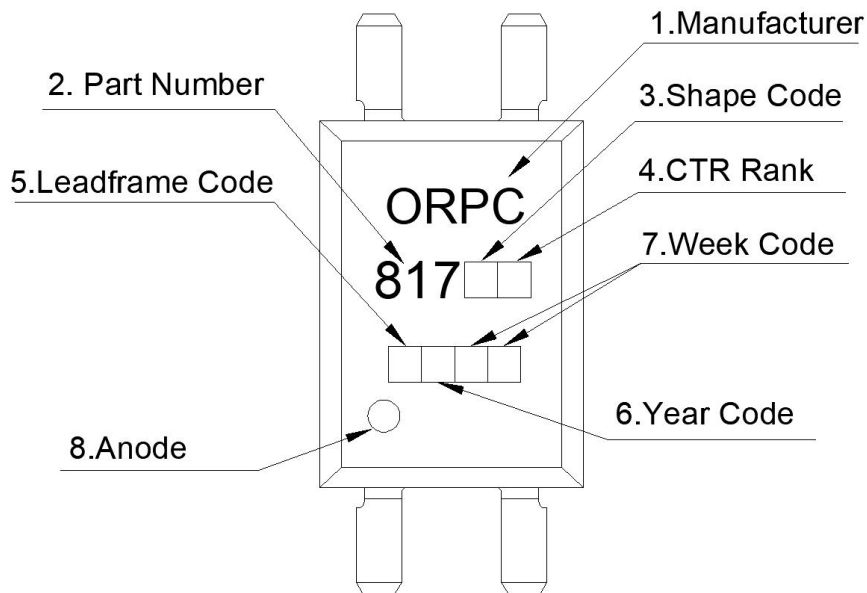

1. Manufacturer : ORIENT.
2. Part Number : 817.
3. Shape Code .
4. Rank Code : CTR Rank
5. Lead frame Code : 'F' means Iron, 'C' means Copper.
6. Year Code : '1' means '2021' and so on.
7. Week Code : 01 means the first week, 02 means the second week and so on.
8. Anode.

10. Package Dimension (Unit: mm)

S Type

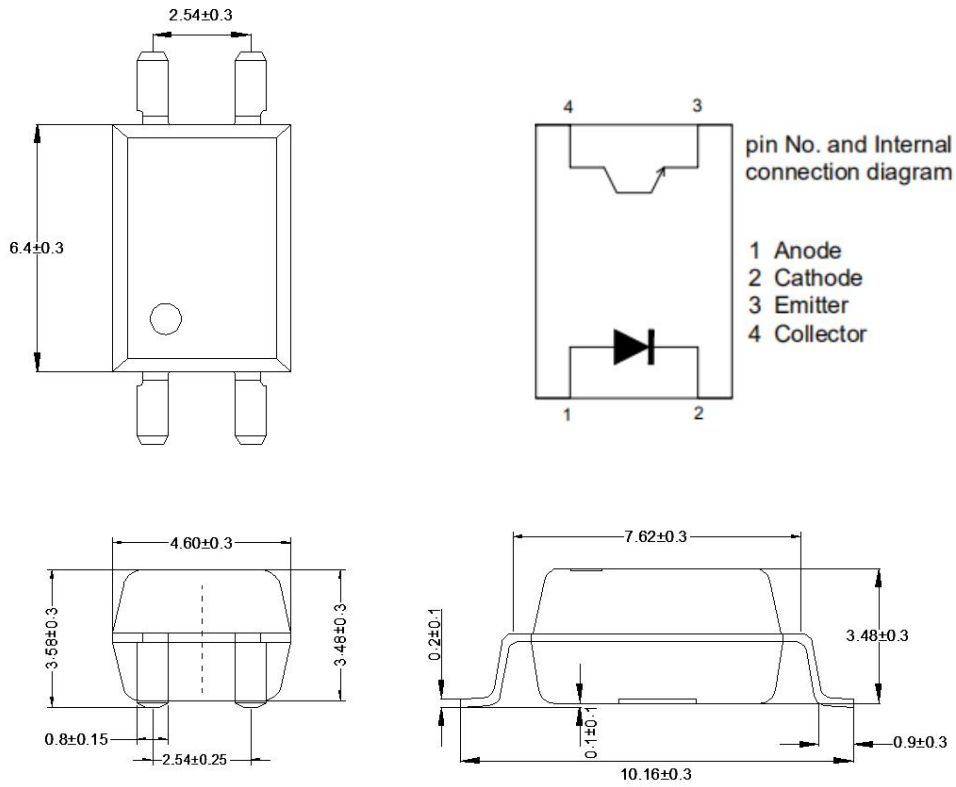

11. Taping Dimensions

(1) TP Type

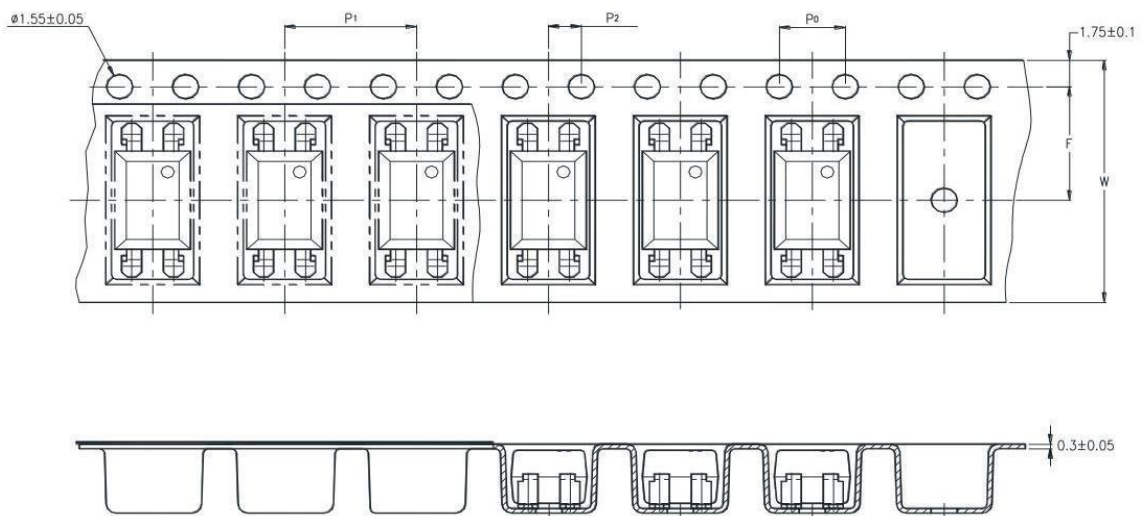

(2)TP1 Type

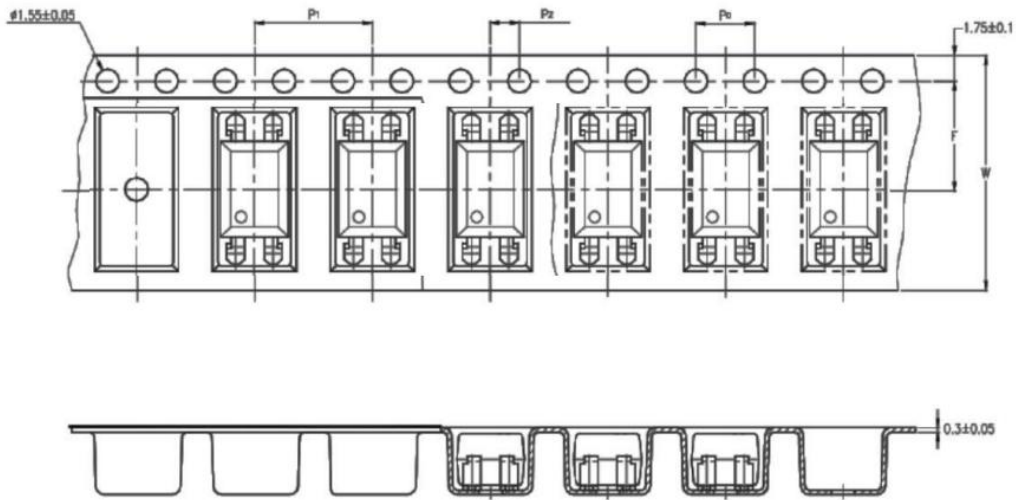

Description	Symbol	Dimension in mm (inch)
Tape wide	W	16±0.3 (.63)
Pitch of sprocket holes	P ₀	4±0.1 (.15)
Distance of compartment	F	7.5±0.1 (.295)
	P ₂	2±0.1 (.0079)
Distance of compartment to compartment	P ₁	8±0.1 (.472)

Package Type	TP/TP1
Quantities(pcs)	2000

12. Recommended Foot Print Patterns (Mount Pad) (Unit: mm)

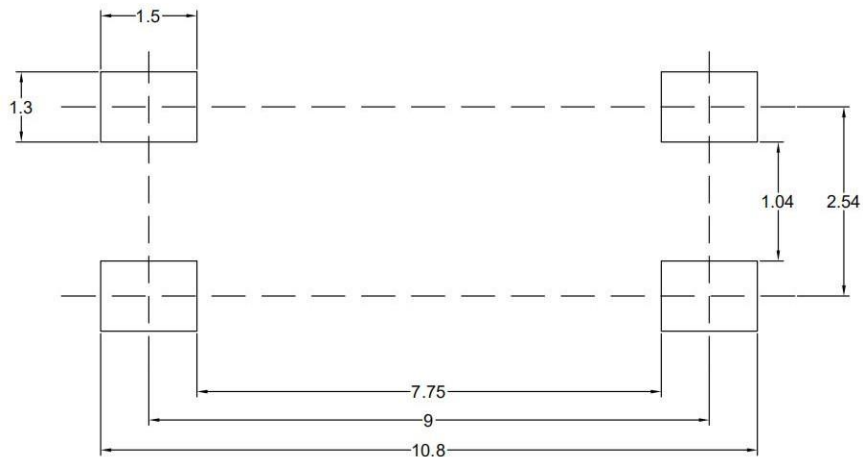

13. Package Dimension

SOP Type

Packing Information	
Packing type	Reel type
Tape Width	16mm
Qty per Reel	2,000pcs
Small box (inner) Dimension	345*345*58.5mm
Large box (Outer) Dimension	620x360x360mm
Max qty per small box	4,000pcs
Max qty per large box	40,000pcs

(2)Packing Label Sample

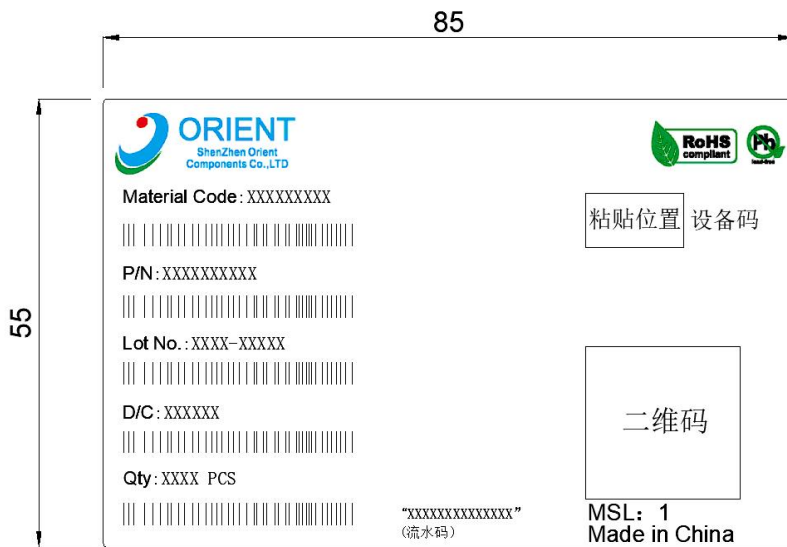

Note:

1. Material Code :Product ID.
2. P/N :Contents with "Order Information" in the specification.
3. Lot No. :Product weeks.
4. D/C :Product data.
5. Quantity :Packaging quantity.

14. Temperature Profile Of Soldering

(1).IR Reflow soldering (JEDEC-STD-020 compliant)

One time soldering reflow is recommended within the condition of temperature and time profile shown below. Do not solder more than three times.

Profile item	Conditions
Preheat	
- Temperature Min (T Smin)	150°C
- Temperature Max (T Smax)	200°C
- Time (min to max) (ts)	90±30 sec
Soldering zone	
- Temperature (TL)	217°C
- Time (t L)	60 sec
Peak Temperature	260°C
Peak Temperature time	20 sec
Ramp-up rate	3°C / sec max.
Ramp-down rate from peak temperature	3~6°C / sec
Reflow times	≤3

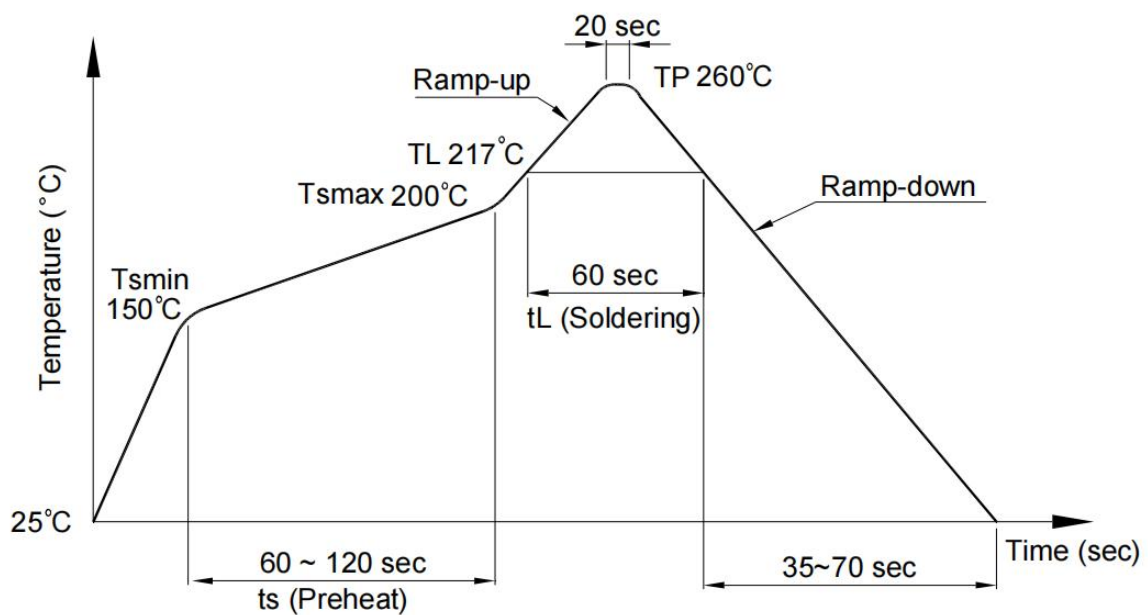

(2).Wave soldering (JEDEC22 A111 compliant)

One time soldering is recommended within the condition of temperature.

Temperature	260+0/-5°C
Time	10 sec
Preheat temperature	25 to 140°C
Preheat time	30 to 80 sec

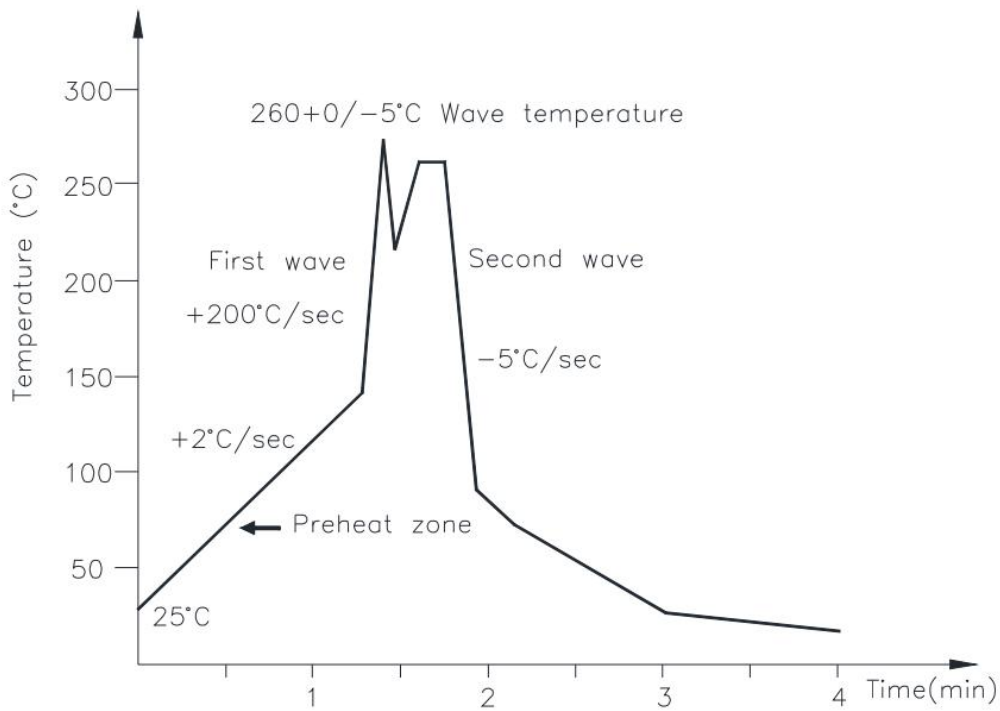

(3).Hand soldering by soldering iron

Allow single lead soldering in every single process. One time soldering is recommended.

Temperature	380+0/-5°C
Time	3 sec max

15. Characteristics Curves

Fig.1 Forward current vs Ambient temperature

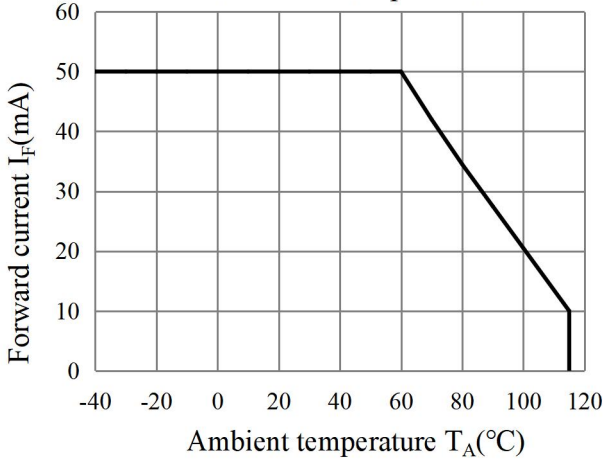

Fig.2 Collector Power Dissipation vs. Ambient temperature

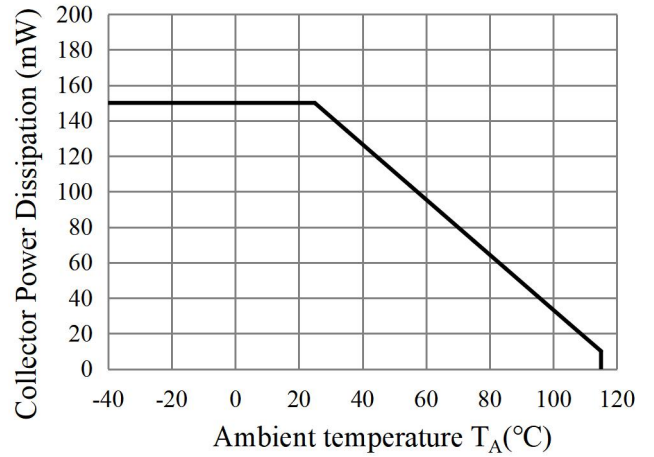

Fig.3 Forward Current vs. Forward Voltage

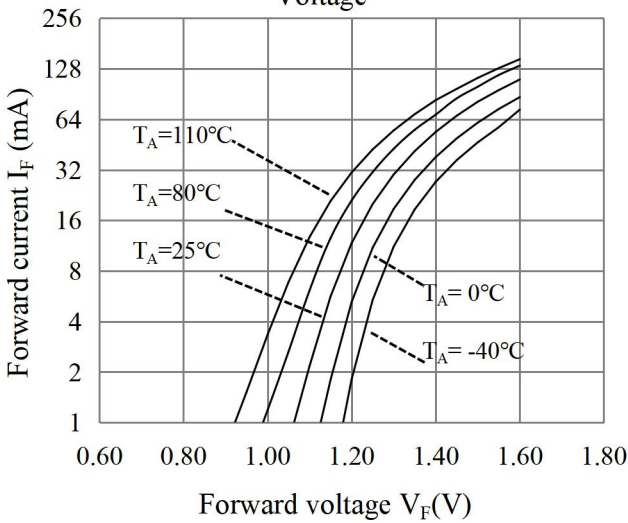

Fig.4 Collector-emitter Saturation Voltage vs. Forward Current

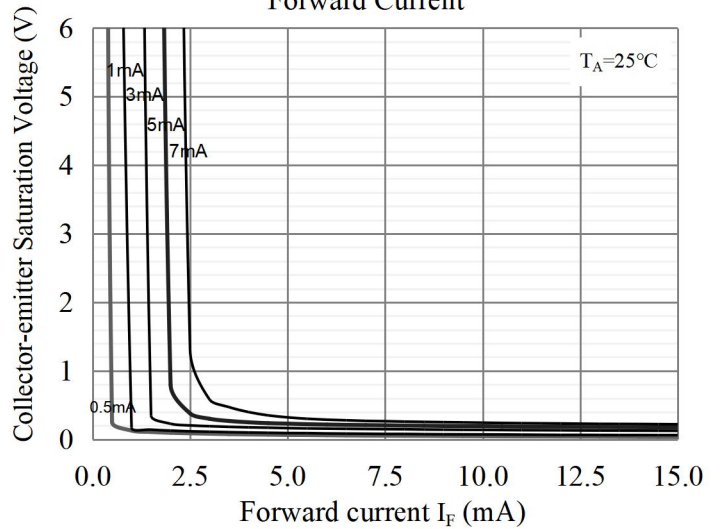

fig.5 Collector Current vs. Non-Saturated Collector Emitter Voltage

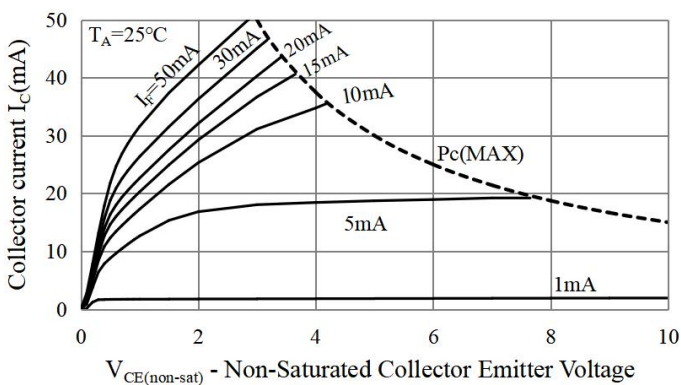

fig.6 Collector Current vs. Non-Saturated Collector Emitter Voltage

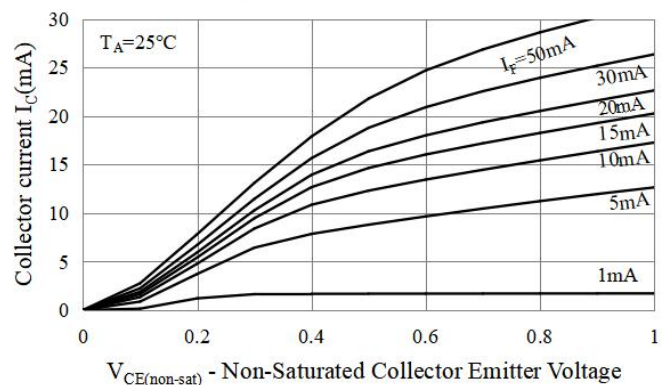

Fig.7 Relative Current Transfer Ratio vs. Ambient Temperature

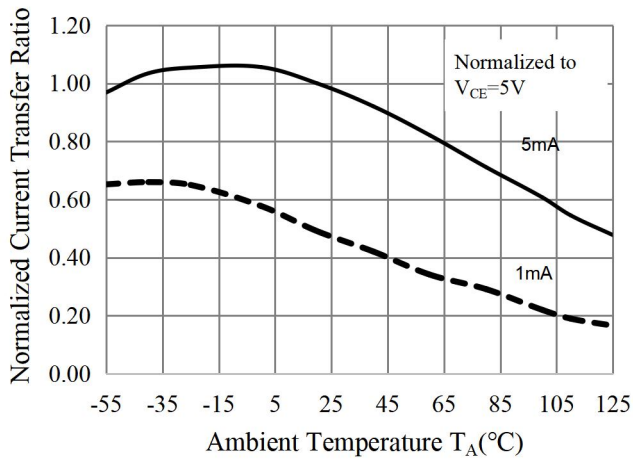

Fig.8 Relative Current Transfer Ratio vs. Ambient Temperature

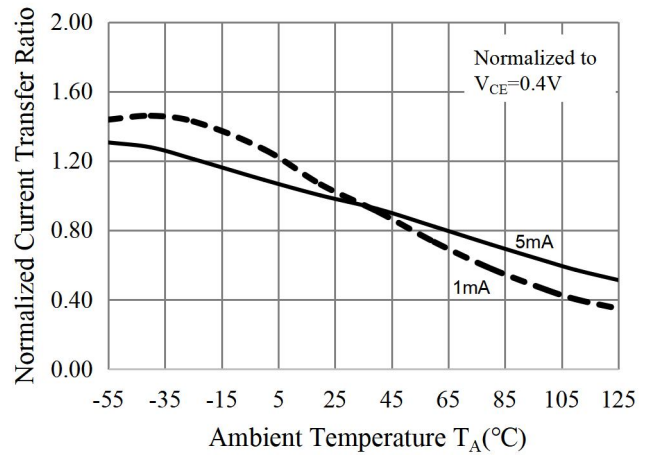

Fig.9 Forward Current vs. Current Transfer Ratio

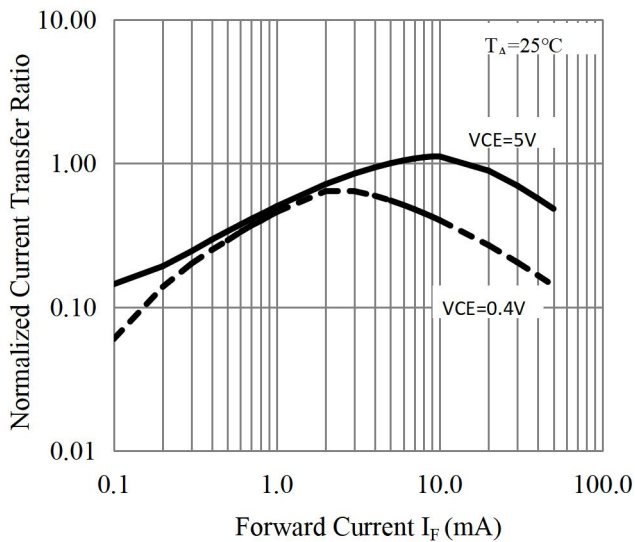

Fig.10 Collector Dark Current vs. Ambient Temperature

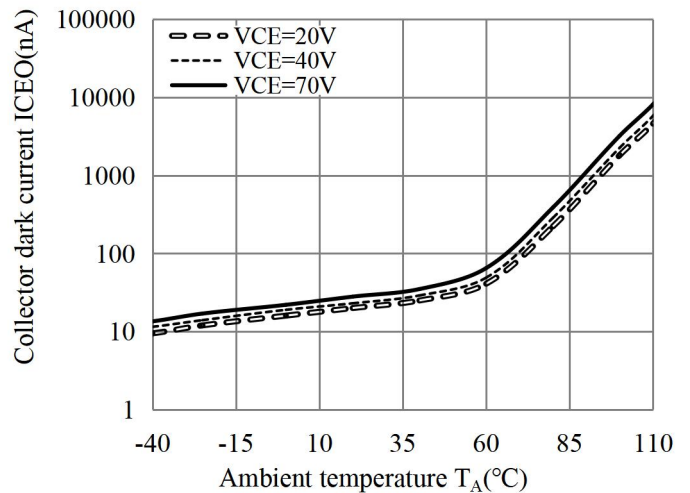

Fig.11 Collector-emitter Saturation Voltage vs. Ambient Temperature

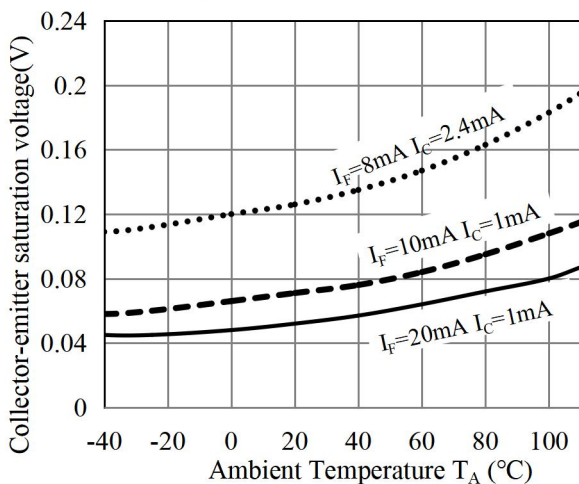

Fig.12 Switching Time vs. Load Resistance

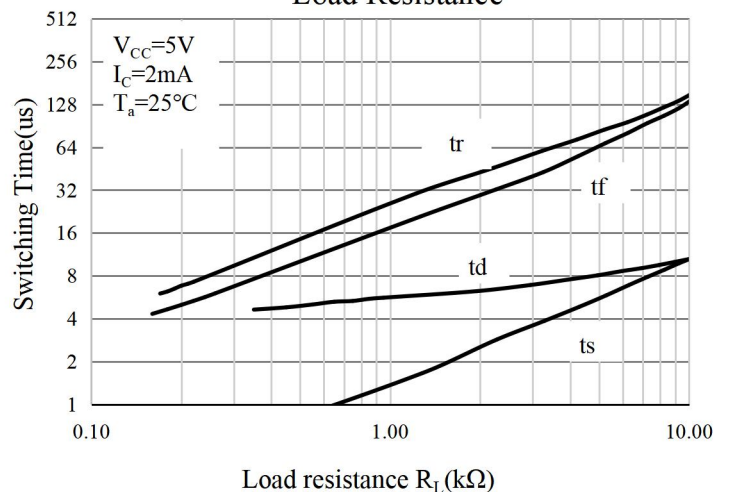

Fig.13 Respinse Time vs. Ambient temperature

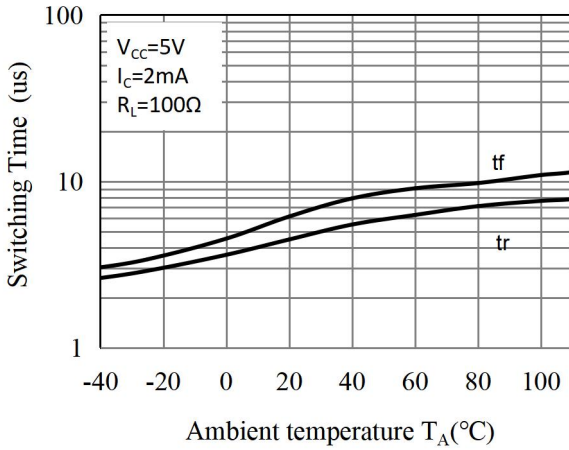
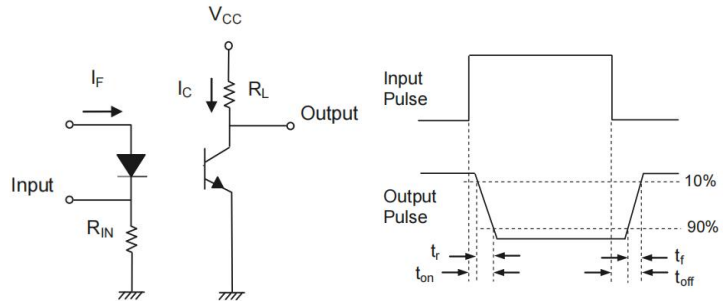

Fig.14 Switching Time Test Circuit & Waveforms



16. NOTES

1. Orient is continually improving the quality, reliability, function or design and Orient reserves the right to make changes without further notices.
2. The products shown in this publication are designed for the general use in electronic applications such as office automation equipment, communications devices, audio/visual equipment, electrical application and instrumentation.
3. For equipment/devices where high reliability or safety is required, such as space applications, nuclear power control equipment, medical equipment, etc, please contact our sales representatives.
4. When requiring a device for any "specific" application, please contact our sales in advice.
5. If there are any questions about the contents of this publication, please contact us at your convenience.
6. The contents described herein are subject to change without prior notice.
7. Immerge unit's body in solder paste is not recommended.